

10

PRACTICAL SUGGESTIONS

BY

ROBERT RAWLINSON, Esq., C.B.,
GOVERNMENT ENGINEER,



IN REFERENCE TO

SEWERAGE, DRAINAGE, AND WATER SUPPLY

OF

LUNATIC ASYLUMS

ISSUED BY

THE COMMISSIONERS IN LUNACY.



LONDON:

PRINTED BY GEORGE E. EYRE AND WILLIAM SPOTTISWODE,
PRINTERS TO THE QUEEN'S MOST EXCELLENT MAJESTY,
FOR HER MAJESTY'S STATIONERY OFFICE.

1870.

PRACTICAL SUGGESTIONS

ON

SEWAGE, DRAINAGE, AND WATER SUPPLY

OF

LUNATIC ASYLUMS.

Sewerage and Drainage.

Before a scheme of sewerage is devised, the site should be fully examined so as to obtain a correct idea of the drainage area, or the several drainage areas. Site.

1. Main sewers and drains should be adapted to the buildings and yard areas, surface area of roofs, and volume of water supply. Main sewers.

2. Sewers and drains, in wet subsoil, should be made to act as land drains. Wet subsoils.

3. Natural streams should not be arched over to form main sewers. Natural streams

4. Main sewers need not be of capacity to contain flood-water of the area drained; such flood-water may be passed over the surface, in most cases, without causing injury. Flood-waters.

5. Main sewers should be laid out in straight lines and true gradients from point to point, with manholes, and flushing and ventilating arrangements at each principal change of line and gradient. All manholes should be brought up to the surface to allow of inspection, and should be furnished with a cover easily removable, and each manhole should be ventilated. (See drawing No. 1.) Sewers to be in right lines.
Manholes.

6. Duplicate systems of sewers are not required. Drains to natural streams in valley lines for storm waters may be retained, and may be improved, or if necessary, enlarged. Duplicate sewers not required.

7. Earthenware pipes make good sewers and drains up to their capacity; they must however be truly laid, and securely jointed. In ordinary ground they may be jointed with clay; in sandy ground, with concrete, to prevent sand washing in at the joints. House drains should, in all cases when laid, be watertight; and if the subsoil is porous, the trench should first be lined with clay puddle, special care being taken to prevent any chance of contamination of local wells by sewage. Earthenware pipes.

8. Brick sewers (see drawing No. 4) ought to be formed with bricks moulded to the radii. Bricks for sewers.

9. Bricks in sewers should, in all cases, be set in "hydraulic mortar" or in cement. Cement.

10. Sewers should not join at right angles. Tributary sewers should deliver sewage in the direction of the mainflow. Junction of sewers.

- Extra fall at junctions. 11. Sewers and drains, at junctions and curves, should have extra fall (3 inches) to compensate for friction.
- Inverts of tributary sewers to have extra fall. 12. Sewers of unequal sectional diameters should not join with level inverts, but the lesser or tributary sewer or drain should have a fall into the main, at least equal to the difference in the sectional diameter.
- Earthenware pipes, how to join. 13. Earthenware pipes of equal diameters should not be laid as branch or tributary drains, that is, 9 ins. leading into 9 ins., or 6 ins. into 6 ins.; but a lesser pipe should be joined on to the greater, as 12 ins. to 15 ins., 9 ins. to 12 ins., 6 ins. to 9 ins.
- Drains not to enter buildings. 14. Drains should not pass direct from sewers to the inside of wards or houses, but all drains should end at an outside wall, at a manhole-shaft, and drains, sink-pipes, and soil-pipes should have ample means of external ventilation provided from the manhole shaft.
- Flues in walls not to ventilate sewers. 15. Sewers and drains should not be ventilated by flues constructed in the walls of an inhabited building, but by ventilating shafts external and independent.
- Sinks to be against external walls. 16. Sinks and water closets should be against external walls, so that the refuse-water or soil may be discharged into a drain commencing from a fully ventilated shaft outside the main wall.
- Drains to be protected. 17. Surface inlets to all pipe-drains should be properly protected.
- Side junctions. 18. Side junctions should be provided in all sewers and drains. The position should be sketched and indicated by figures in a book or on a plan, and any side junctions not required at once should be carefully closed for subsequent use.
- Record of substrata to be kept. 19. A record should be kept by the surveyor of the geological character of the subsoil opened out as it is being sewered or drained.
- Tall chimneys may ventilate. 20. Tall chimneys (steam boiler chimneys) may be used with advantage, but must not wholly be depended upon, for sewer and drain ventilation.
- Sewer outlets to be protected. 21. Sewer outlet works (see drawing No. 2.) should be simple in form, and so arranged as to remove solids, sediment, and flocculent matter from the sewage. Outlet sewer ends should be protected to prevent wind blowing in and so driving sewage gases back.

General Remarks.

- Deep trenches dangerous. In executing sewers and drains danger may be anticipated from several conditions, as, where the trench is deep, and the substrata consists of made ground, loose earth, bog, silt, quicksand, or any combination of such strata,

Quicksand is most difficult to deal with, and, as a rule, such ground should only be opened in short lengths; this ground may require to be close timbered, and in such case, stable litter and ashes will be found useful to pack behind and betwixt the "polling boards."

Quicksands,
how to be dealt
with.

Sound looking clay or marl may require careful timbering to prevent heavy breakings from the sides of the trench, as when such ground "sets" heavily, the sewer, if of bricks, may be seriously injured; if of earthenware pipes it may be ruined by cracking, crushing, or by distorting the line of sewer or drain pipes.

Clay not to be
trusted unsup-
ported in deep
excavations.

Sewer and drain trenches should be carefully timbered, and such timbering in bad ground must either be left in or be most carefully removed as the trench is filled in. Deep trenches, and where there is special danger, had better be filled with concrete.

Timbering
sewer trenches.

Sewers and drains should be capable of conveying sewage to some common outlet, without retaining sediment. They should have arrangements for full ventilation at such points and in such manner as not to cause any nuisance, but not more than 100 yards apart. Charcoal may be used to filter and disinfect sewage gases at manholes and other ventilators. (See drawing No. 1.)

Purpose of
sewers and
drains.

Manholes should have moveable covers at the surface of the ground. There should be a side-chamber for ventilation, "step-irons" to give access to the invert, and a groove to allow of a flushing board being inserted at will for flushing purposes. The side-chamber may have a charcoal screen or sewage-gas filter. (See drawing No. 1.)

Manholes.

Water Supply.

Where an asylum is to be supplied with water, all other things being equal, the softest and purest water should be adopted.

Quality of
water.

Reservoirs, for service distribution, should be covered, but fully ventilated, and if filters are used the water should not be exposed in open reservoirs and tanks after filtration.*

Reservoirs to
be covered and
ventilated.

Cast-iron pipes, properly varnished, should alone be used for mains. It is not advisable to use mains less in internal diameter than three inches.

Cast-iron pipes
to be varnished.

Lead should not be used for cisterns, but boiler plate, or for large elevated tanks, cast-iron.

Lead not to
be used for
cisterns.

In jointing and fixing wrought-iron service-pipes, care should be taken to insert double screw-joints at convenient points, to allow of the removal of a length of pipe for alteration and repairs. Up-bends should also be avoided.

Jointing iron
service pipes.

Wrought-iron service pipes are cheaper, stronger, and more easily fitted than service-pipes of lead.

Service pipes.

Earthenware pipes may be used for water conduits, provided the joints are not placed under pressure.

Conduits.

Shallow wells are liable to pollution from vegetable matter, or even from animal matter in the surface soil, unless the brick lining is set in cement or there is a lining of cast-iron. Cylinders

Wells, how to
be lined.

* For plan and section of Filter Beds see drawing No. 3.

of cast-iron are sometimes used to exclude the surrounding subsoil water.

Springs to be stored. Natural springs may be utilized by storing the water in a reservoir which will contain the flow of one entire day, or longer period; and such reservoirs should be walled with masonry, and be covered in and ventilated to protect the water from contamination.

Aqueducts, how to be graded. Springs of water, at a distance, may be conducted in channels contouring the intervening distance. The fall of a conduit may vary according to circumstances, but should not be less than one in 1,000, nor greater than one in 300, unless cast-iron pipe conduits are used.

Trench to be water-tight. In forming an earthenware pipe conduit, great care must be taken, first, to make the trench water-tight, and then to lay and joint the pipes so as to secure that the conduit shall be sound and water-tight through its whole length, to prevent leakage from the pipes into the subsoil, and to obviate the risk of impure water from the subsoil entering the conduit pipe.

Conduits, how to be formed. In forming an aqueduct the pipes should be laid in straight lines, from point to point. There should be manholes for inspection and ventilation at all curves. The radius of all curves should be ten times the diameter of the conduit. There should be manholes for ventilation and inspection in each quarter mile. There should also be means of washing out at all convenient points.

Valleys, how to be crossed. Valley lines may be crossed by means of cast-iron syphon pipes, which should have double the fall in their length of the ordinary conduit; and there should be a sluice-valve provided to wash out and cleanse such syphon pipe or pipes at the lowest point.

Pure Water Tanks.

Store tanks to be covered. Tanks for storing water should either be arched over or be roofed so as to protect the water from the direct action of the sun and from fouling, and should be fully ventilated.

Ground to be water-tight. The ground excavated for the formation of a tank, should first be made perfectly water-tight; the bottom may be covered with clay puddle, and the side walls be backed or lined with clay puddle. The thickness of the puddle should not be less than 12 inches.

How tanks may be formed. If the site selected for a tank is sand, gravel, or open jointed rock, great care must be taken to give the puddle a full and even bearing over the whole surface area; open joints in rock must be cleaned out and then be filled up with concrete. In gravel, large stones must be removed, and the entire surface brought to a level, smooth, and even plain. Clay puddle will only resist the pressure of water when it rests solidly on an even bed, so as to prevent the water forcing holes through it, which will be the case if there is a rough uneven porous surface, with open spaces beneath.

Plans.

General plan of not less than 5 feet to a mile to be provided. A general plan drawn to a scale not less than 5 feet to the mile should be provided, on which the several blocks of buildings may

Note.—Five feet to the mile is the Ordnance scale for town portions.

be exhibited. On this plan the lines of sewers and drains, with position of manholes and ventilating shafts should be shown, and in cases of alterations or additions being made, these changes should be recorded so that the actual position of any sewer, drain, manhole, or point of ventilation may be ascertained at once.

A duplicate plan should show the lines of water supply pipes. Wells, cisterns, tanks, waste water overflow, and fire service hydrants, water supply tanks, and service pipes should be protected from the action of frost, and should be easy of access, for examination, cleansing, or repairs. Duplicate plan.

Hydrants for fire service, to be effective, should be so situate as not to require a greater length of hose than 60 feet, to reach the parts to be protected; they may therefore be fixed 120 feet apart. Fire service arrangements.

Sewage Irrigation.

Sewage may be used for agricultural purposes with advantage, if proper knowledge and care are made available. Sewage to be used with care.

Sewage contains the elements of every field or garden crop which is grown, and compared with solid manure there are advantages in using fluid sewage. The water of sewage in dry weather is alone of great value. 224 gallons (one ton) of sewage are, in summer, worth about twopence compared with Peruvian guano at 11 $\frac{1}{2}$ per ton. Sewage contains the elements of manure.

Sewage may be applied to common grass, to Italian rye grass, and also to root and vegetable crops. Sewage may be applied to grass and to root crops.

The earth possesses the power of extracting and absorbing from sewage all the manure it contains, if the dressings, in volume, are proportioned to the area, to the depth broken up, and to the quality of the land. Sewage grown herbage increases the volume of milk cows will give, and improves the quality of the butter. Sewage grown produce is wholesome. Sewage may be applied to land throughout the year.

Sewage Tanks.

The sewage tanks should be in duplicate, and, if possible, be to the East or North, and not less than 300 feet distant from any inhabited building. There should be a fence wall round not less than seven feet in height. Sewage tanks to be in duplicate.

Irrigation should be with fresh sewage, the volume made each day being passed over some portion of the land. Sewage should be fresh.

One hundred tons of sewage is equivalent to one inch in depth over one statute acre, and for Italian rye-grass 5,000 tons, or 60 inches in depth of sewage, may be applied to each acre per annum. Root crops require much less sewage. Volume of sewage which may be used.

Land requires to be specially prepared and worked for effective sewage irrigation. After it has been deep drained it should be broken up, either by double and deep ploughing, or by spade labour, to a depth of 18 inches. This loosening and working the soil and subsoil enables the sewage to penetrate and become incorporated with the soil. Land to be deep drained and broken up.

Sewage not to
be stagnant.

In irrigation there must not be stagnation, neither on the surface nor in the subsoil. The land must be so laid out that the carriers will distribute the sewage in a thin film over the surface, and the subsoil drains should as regularly remove it.

Solids to be
removed.

Paper, rags, and sediment should be strained out of the sewage before it enters the field carriers for irrigation.

Disinfectants
not required.

Disinfectants will not then be required.

ROBERT RAWLINSON.

LONDON:

Printed by GEORGE E. EYRE and WILLIAM SPOTTISWOODE,
Printers to the Queen's most Excellent Majesty.
For Her Majesty's Stationery Office.

[8704.—500.—3/70.]

MANHOLE & VENTILATING SHAFT ON BRICK SEWER WITH DETAILS

Drawing I

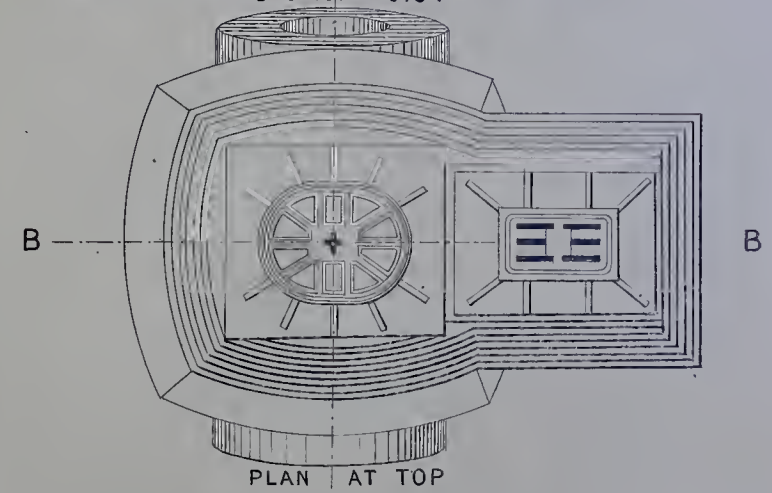
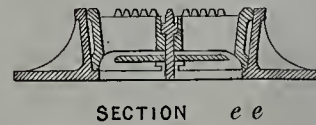
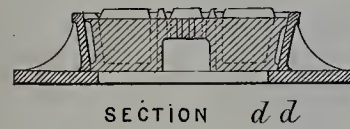
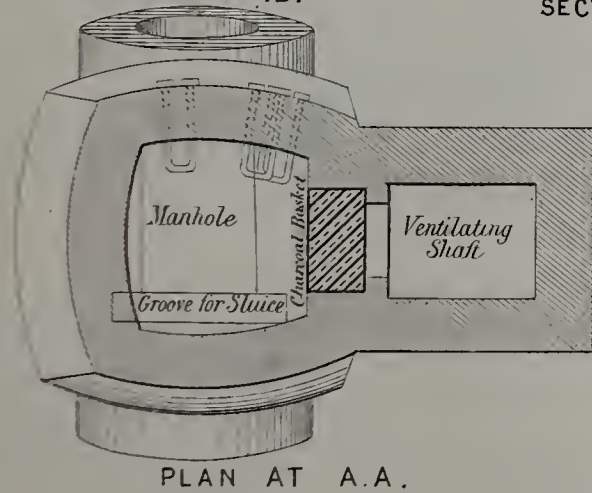
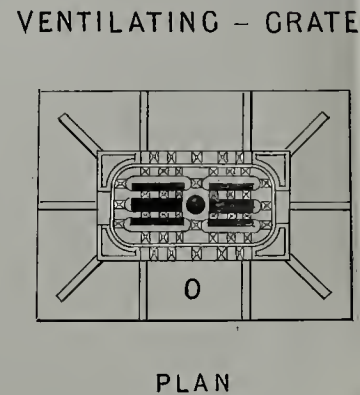
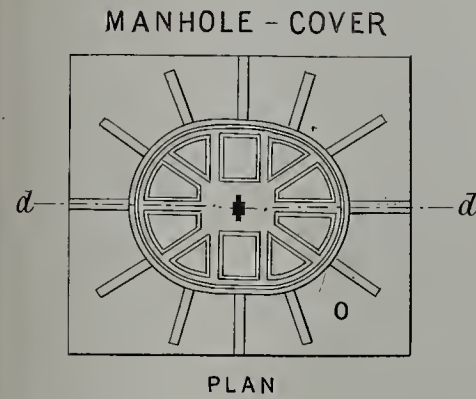
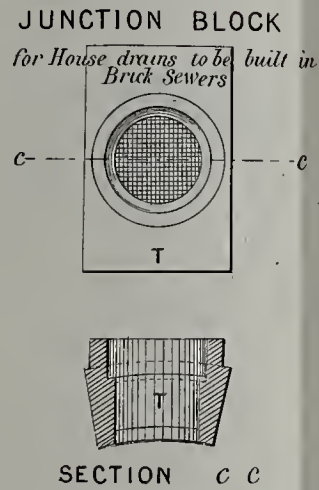
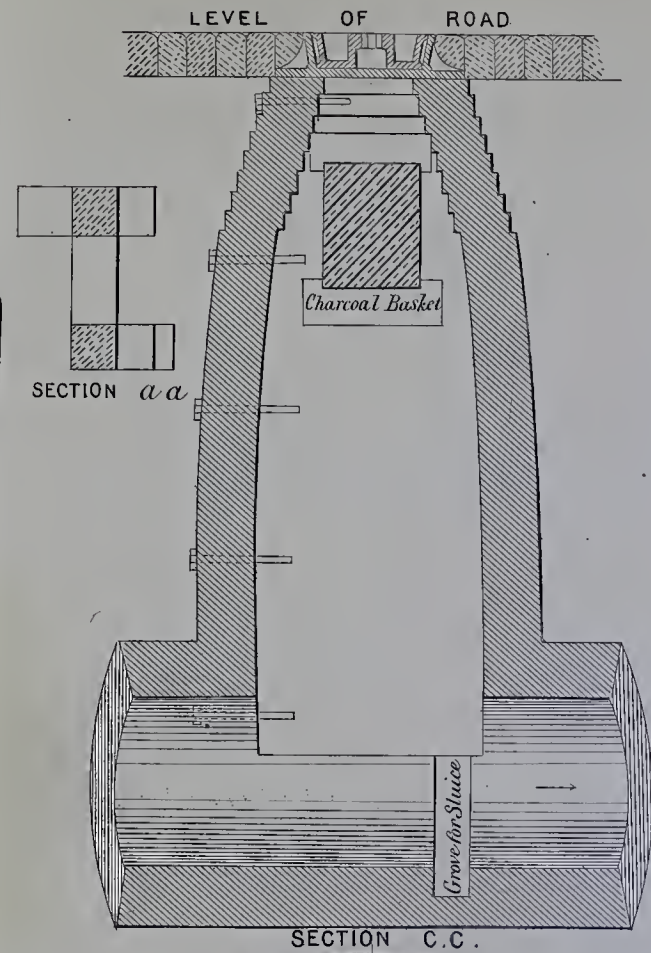
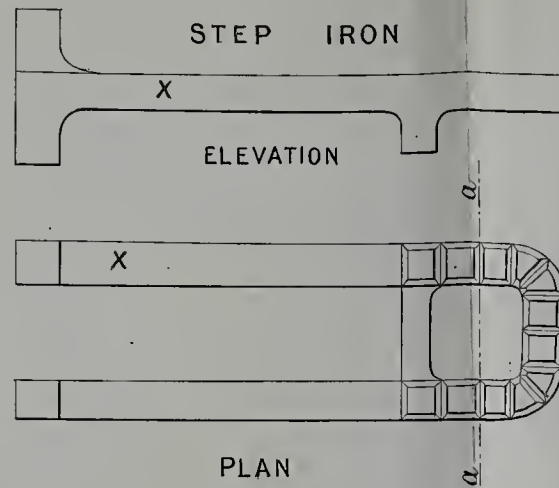
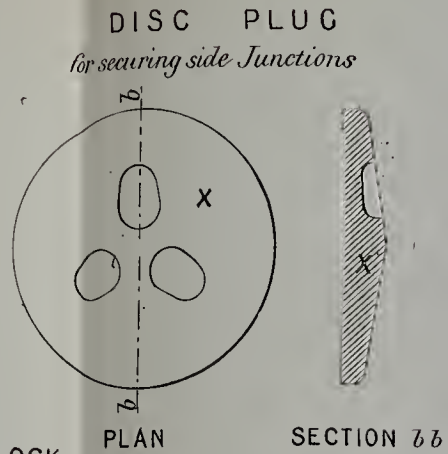
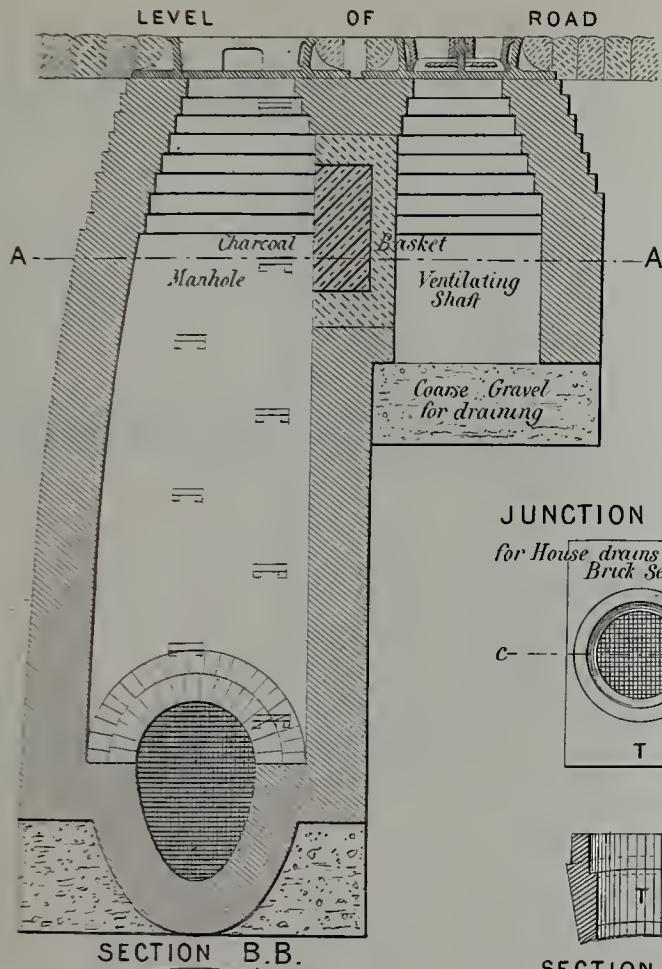

SCALE FOR DETAILS

XXXX Step-Iron and Disc-Plug 2 ins to a foot
 TT Junction Block 3/4 to a foot
 OOO Manhole Cover & Ventilating Grate 1/2 to a foot

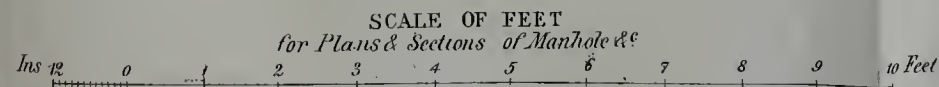

Robert Rawlmsom C.E.

Vincent Brooks Day & Son, Lth.

PLAN OF SEWER OUTLET WORKS.

Drawing II.

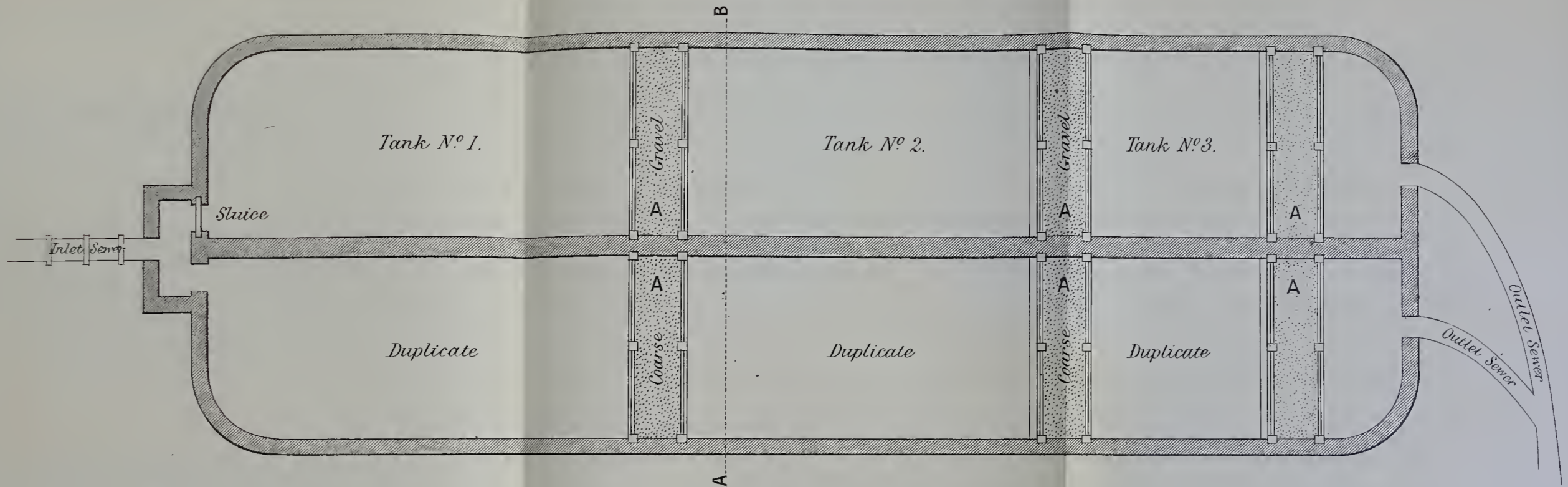

LONGITUDINAL SECTION.

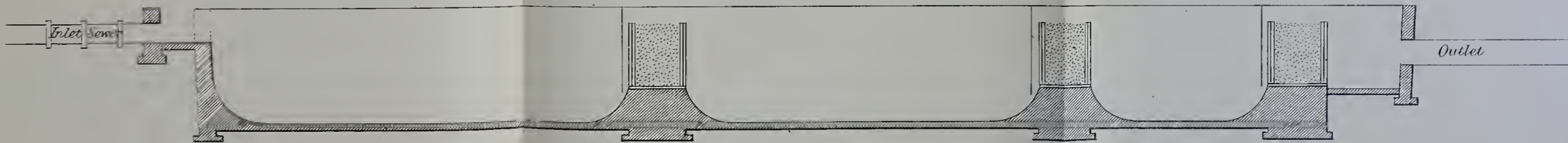

TRANSVERSE SECTION ON LINE A. B.

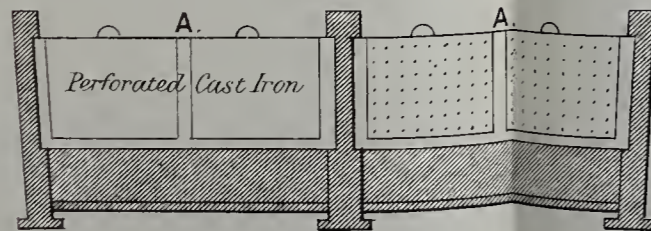

NOTE.

The screens A.A. to be formed of Perforated Cast Iron Boxes fitted with gravel. The Boxes to be made capable of being removed and renewed with gravel when necessary. Each screen may be constructed in two or more compartments.

SCALE.

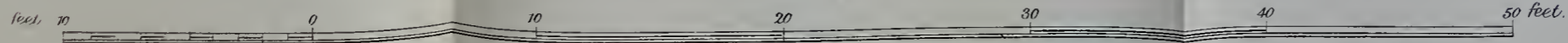

FILTER BEDS.

By these Filters water is passed at the rate of about 150 gallons per superficial foot of sand surface in 24 hours.

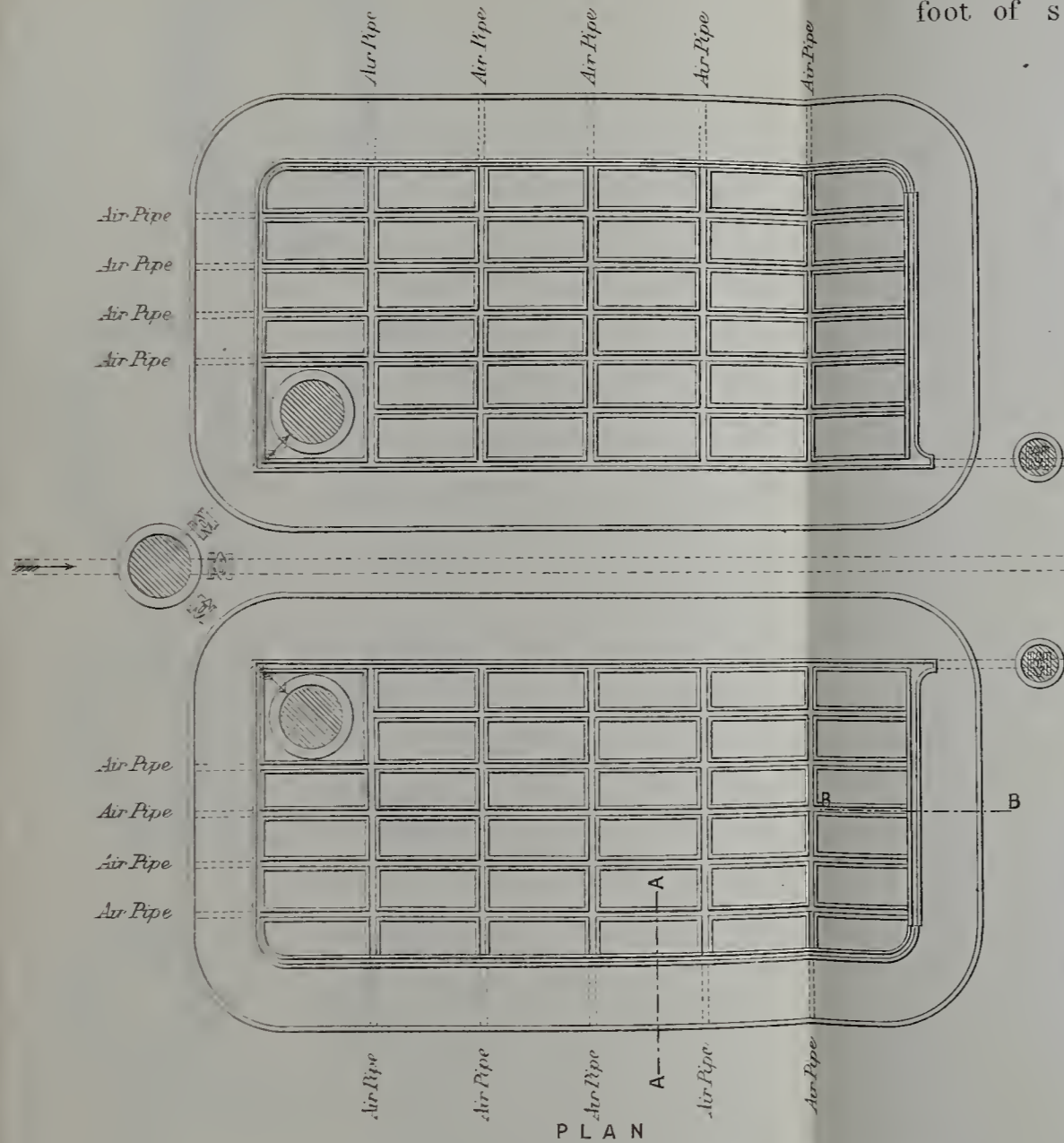

PLAN

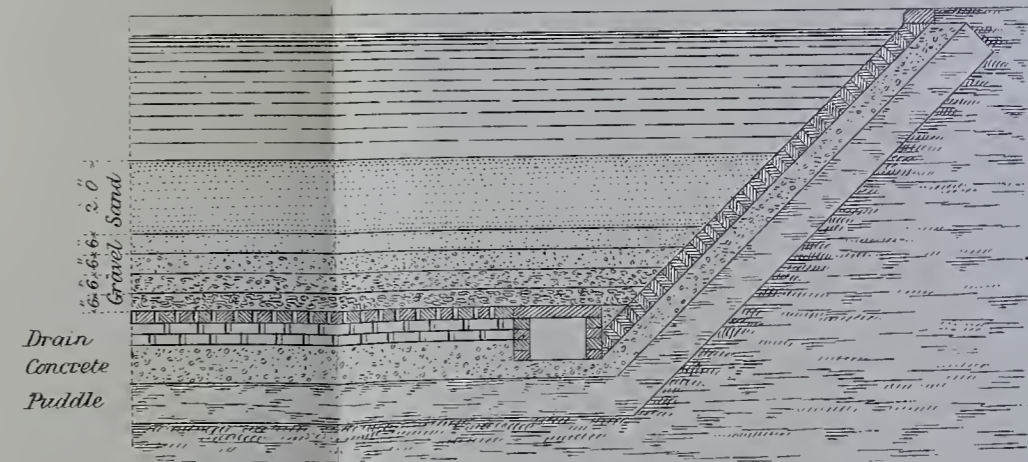
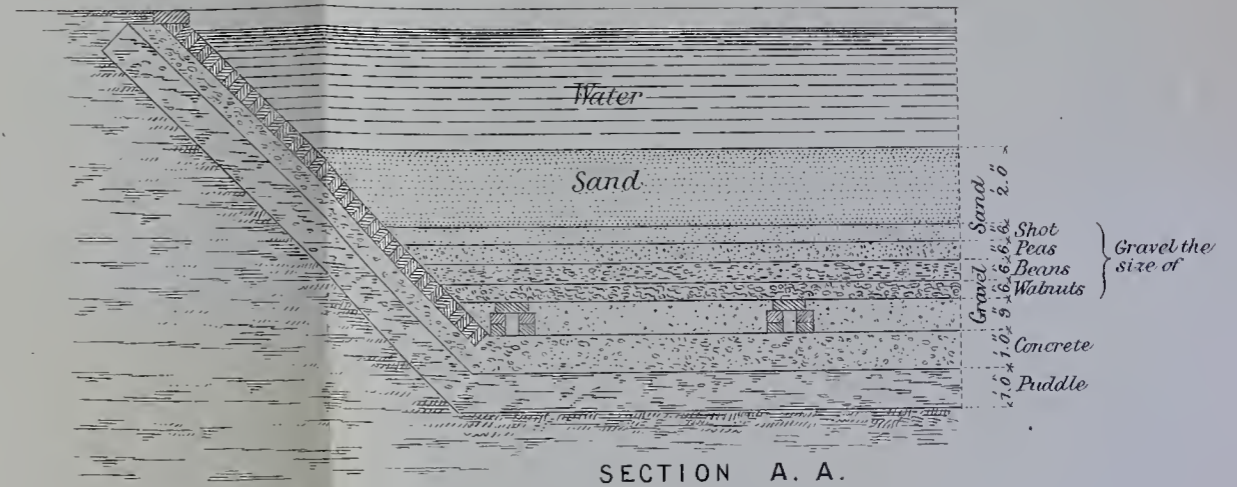
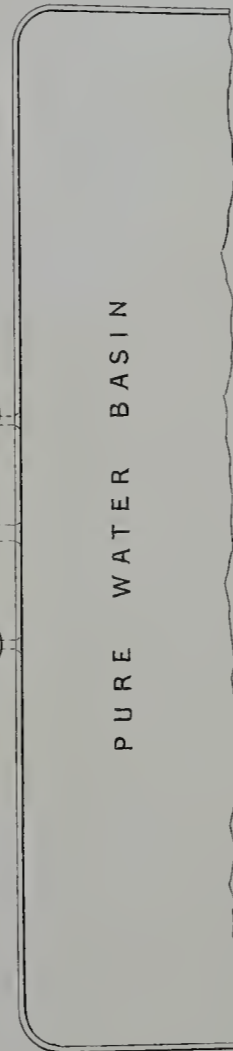
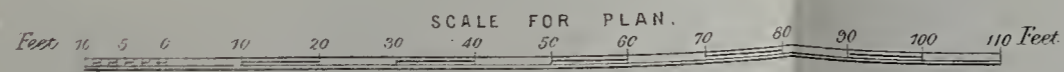

SECTION B. B.

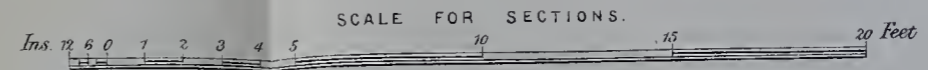

Robert Rawlinson, C.E.

SECTIONS OF BRICK SEWERS

Figs 1, 1^a, 1^b
Area 10.40 Sq.Ft.

	N ^o of Bricks Per lin. yard	Exc. of Invert P ^r lin. yd.
Fig 1	388	1. 18. 10
Fig 1 ^a	384	1. 19. 2
Fig 1 ^b	432	1. 11. 3

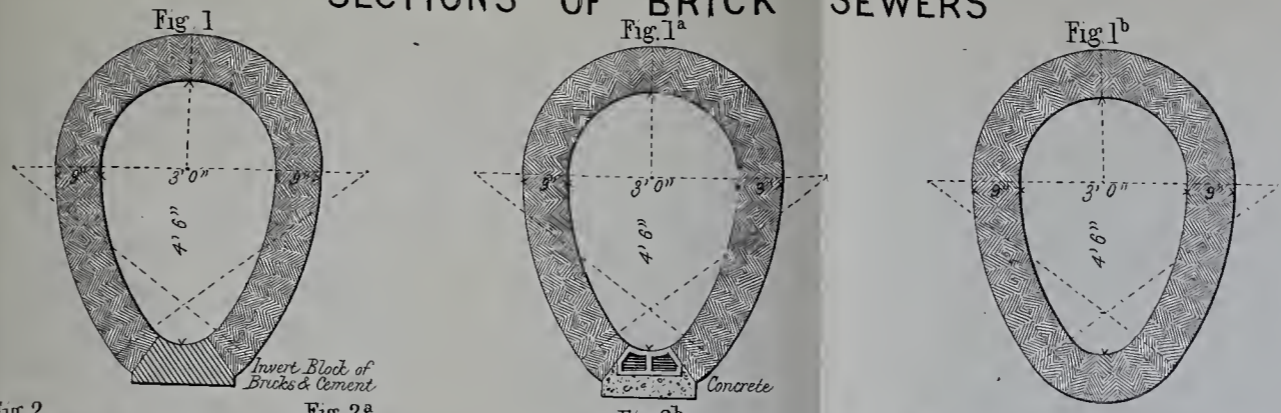

Figs 2, 2^a, 2^b, 2^c, 2^d
area 7.20 Sq.Ft.

Fig 2	336	1. 15. 3
Fig 2 ^a	336	1. 15. 9
Fig 2 ^b	384	1. 13. 10
Fig 2 ^c	156	1. 5. 3
Fig 2 ^d	156	1. 5. 9

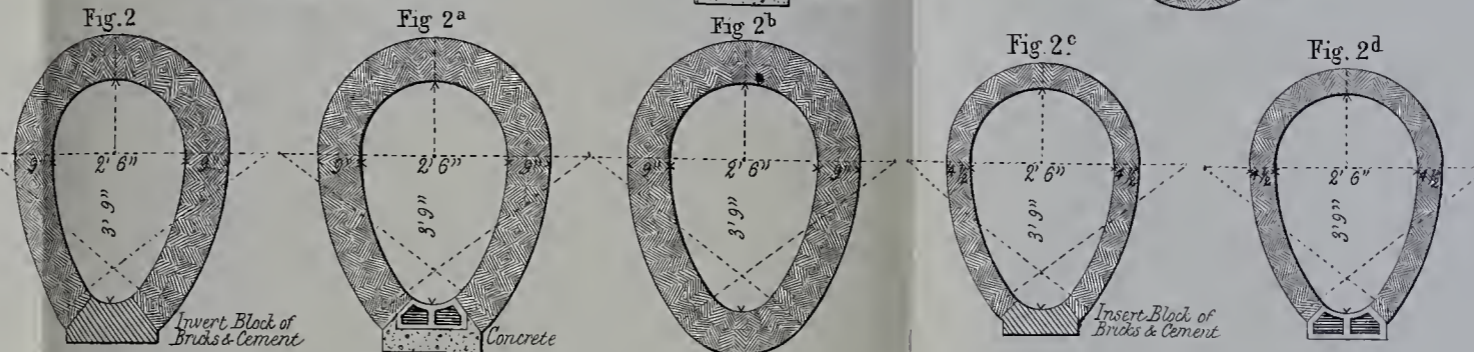

Figs 3, 3^a, 3^b, 3^c, 3^d
Area 4.60 Sq.Ft.

Fig 3	256	1. 10. 2
Fig 3 ^a	256	1. 10. 8
Fig 3 ^b	304	1. 8. 8
Fig 3 ^c	116	1. 2. 4
Fig 3 ^d	116	1. 2. 7

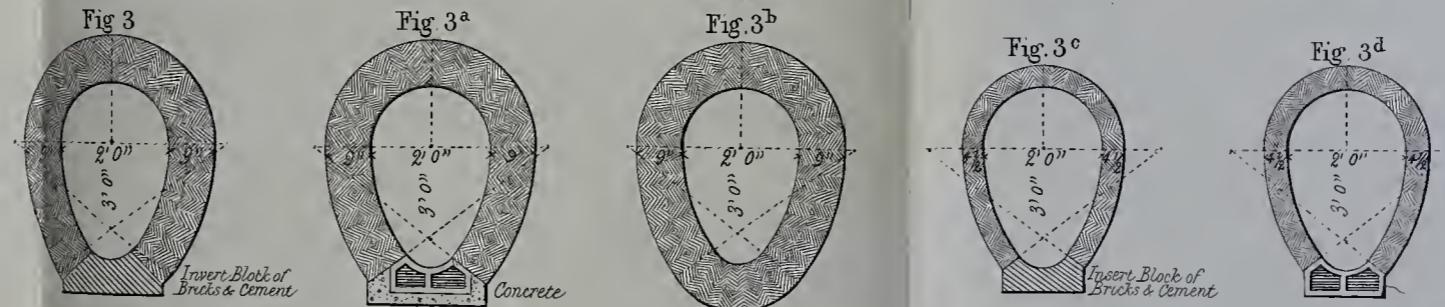

Figs 4, 4^a, 4^b, 4^c, 4^d
Area 3.20 Sq.Ft.

Fig 4	216	1. 7. 6
Fig 4 ^a	216	1. 8. 0
Fig 4 ^b	256	1. 5. 7
Fig 4 ^c	100	1. 0. 9
Fig 4 ^d	100	1. 1. 3

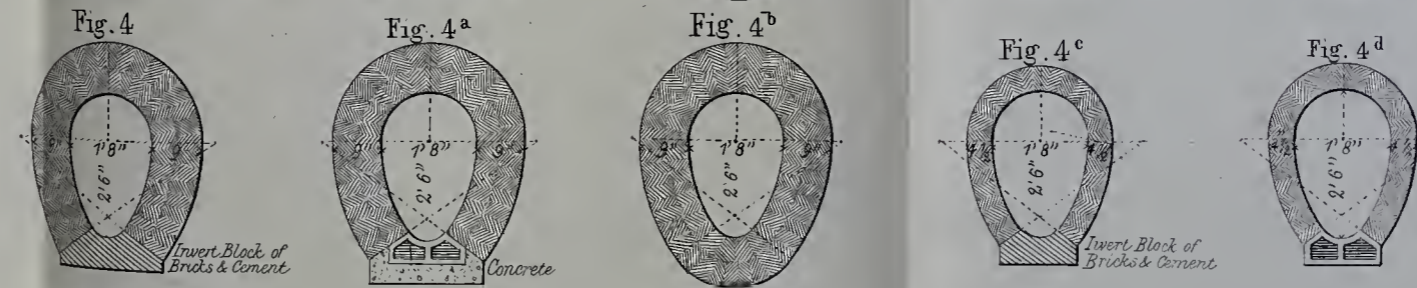

Figs 5, 5^a, 5^b, 5^c, 5^d
area 2.60 Sq.Ft.

Fig 5	208	1. 6. 9
Fig 5 ^a	208	1. 7. 3
Fig 5 ^b	248	1. 4. 11
Fig 5 ^c	92	0. 19. 11
Fig 5 ^d	92	1. 0. 5

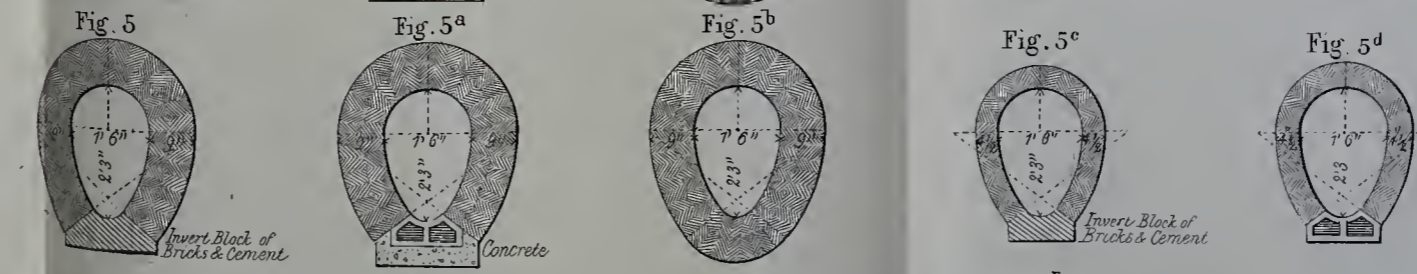

Bricks 30/ per 1000 Mortar 1/2 per 100 Bricks
Excavating 1/2 per 100 Bricks Excavation 1/8 per Cubic Yard

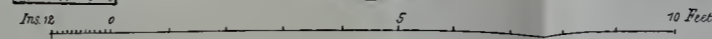

Robert Rowlandson, L.E.

